

SOLANO Top Load Case Packer

> TECHNICAL SPECIFICATIONS

Motion

Continuous

Dimensions

H = 8.9' / 2730mm

L = 8.6' / 2624mm

D = 11.9' / 3652mm

Electrical

480 VAC, 3ph, 60Hz

Safety system

Meets category 3 safety standards

Air pressure

6 bar

Weight

Approx. 2250kg



The SOLANO is more than a top-load case packer, it's a flexible platform with a variety of case packing configurations to match your exact requirements. Our flexible infeed systems can be adapted easily for a variety of packaging, such as bags, pouches, cartons, tubs and cans. With its open build design, SOLANO is easy to use, access and clean. Its operation is intuitive and is complemented by the incorporation of our latest intelligent machine interface (IMI) technology, which provides easy navigation for maintenance and changeover procedures.

> OUTPUT

Speed: 15 cases/min.

Dimensions:

L = 7.08-24.4" / 180-620mm

W = 6.49-16.06" / 165-408mm

D = 6-16.53" / 152-420mm

Combined Case Dimensions:

L + W = 16.33-37" / 415-940mm

W + D = 13.78-29.13" / 350-740mm

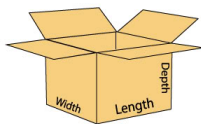

The open design permits a 360-degree view of the working process and great accessibility.

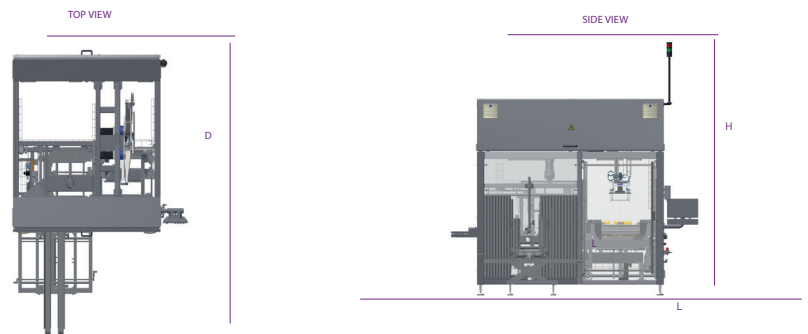

> CAPABILITIES

Infeed



Cartoning



Case Packing



Palletizing

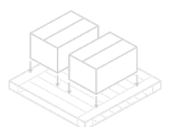

SOLANO Top Load Case Packer

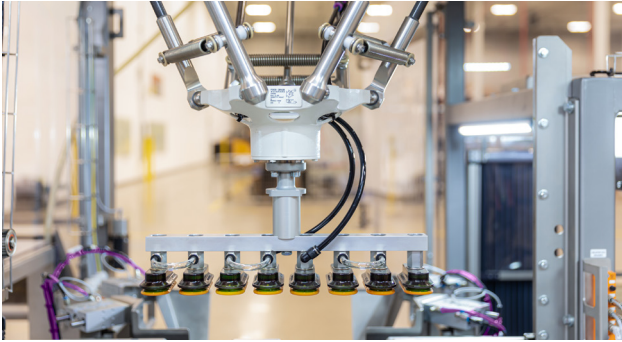

STANDARD FEATURES

- › Left or right hand model available
- › Magazine capacity 48"/ 1200mm
- › 2D robot - 35kg payload
- › CE, UL/ CSA certified
- › Polycarbonate (clear) protection
- › Meets category 3 safety standards
- › IP-rating 54
- › Fixed interface with IPC
- › Allen Bradley controls
- › Tape closure
- › Simple infeed module
- › Electrical cabinet located on top of machine

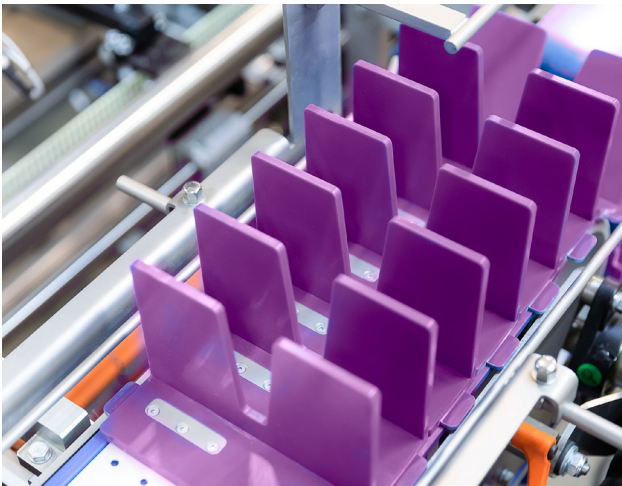

OPTIONAL FEATURES

- › Additional end of arm tool for various product formations
- › Product specific infeed systems for bags, pouches, cartons, tubs, cans
- › Case tilting for side loading products
- › Increased speeds up to 20 cases/ min (dependent on application)
- › Funnel unit for carton loading
- › Open flap detection
- › Case equalization unit
- › Turning head on 2D pick and place unit
- › Labeller/ Printer integration
- › Ground level/ separate electrical cabinet

All information provided in this document is dependent upon final machine specification, infeed arrangement, product type and bag specification

7945-05-2020

Part of Mpac



AMERICAS

+1 905 670 7200
sales.americas@mpac-group.com
service.americas@mpac-group.com

EMEA

+31 24 648 66 55
sales.emea@mpac-group.com
service.emea@mpac-group.com

APAC

+66 2 302 1415 / +65 63 39 96 66
sales.asia@mpac-group.com
service.asia@mpac-group.com